

FOR SUGAR AND SALT INDUSTRY



14, rue de l'Industrie Zone Ind.

F - 33500 LIBOURNE

TÉL. : + 33 (0) 5 57 51 87 89

access.bt@hamsa.fr

# HIGH-PERFORMANCE SCRAPER FOR CONVEYOR BELTS

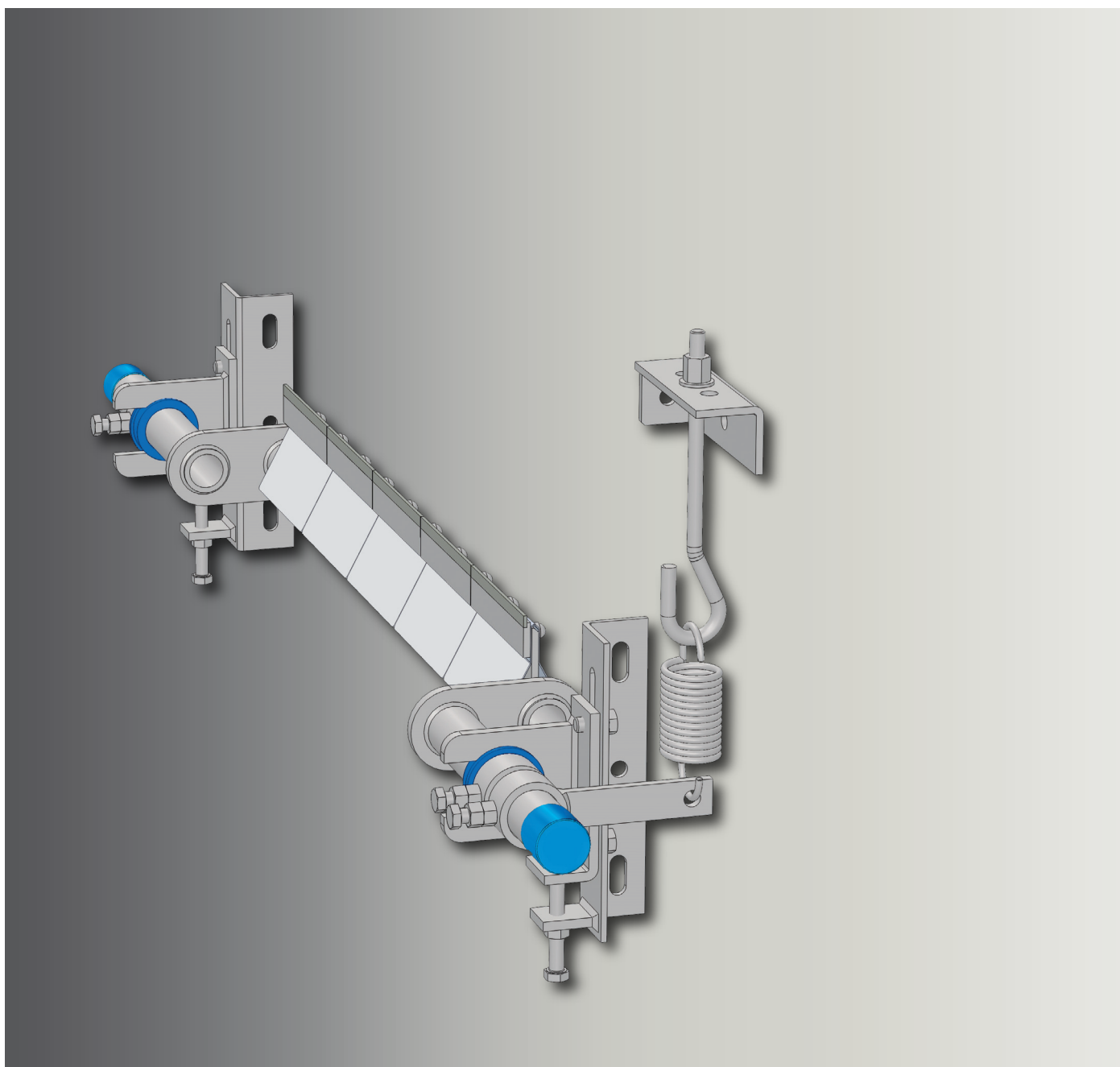

**acman**<sup>®</sup> / RDS



The **acman® / RDS Scraper** was created to clean white PVC or rubber conveyor belts in sugar refineries and the salt industry.

This product meets the stringent requirements of the food industry with a set of 316 stainless steel components and BELLE BANNE 440 hardened stainless steel blades.

The **acman® / RDS Scraper** is designed for single-direction belts, but a reversible version can also be supplied.

A pressure roller or equivalent adaptation is allows to stabilise the belt for long-lasting efficiency.

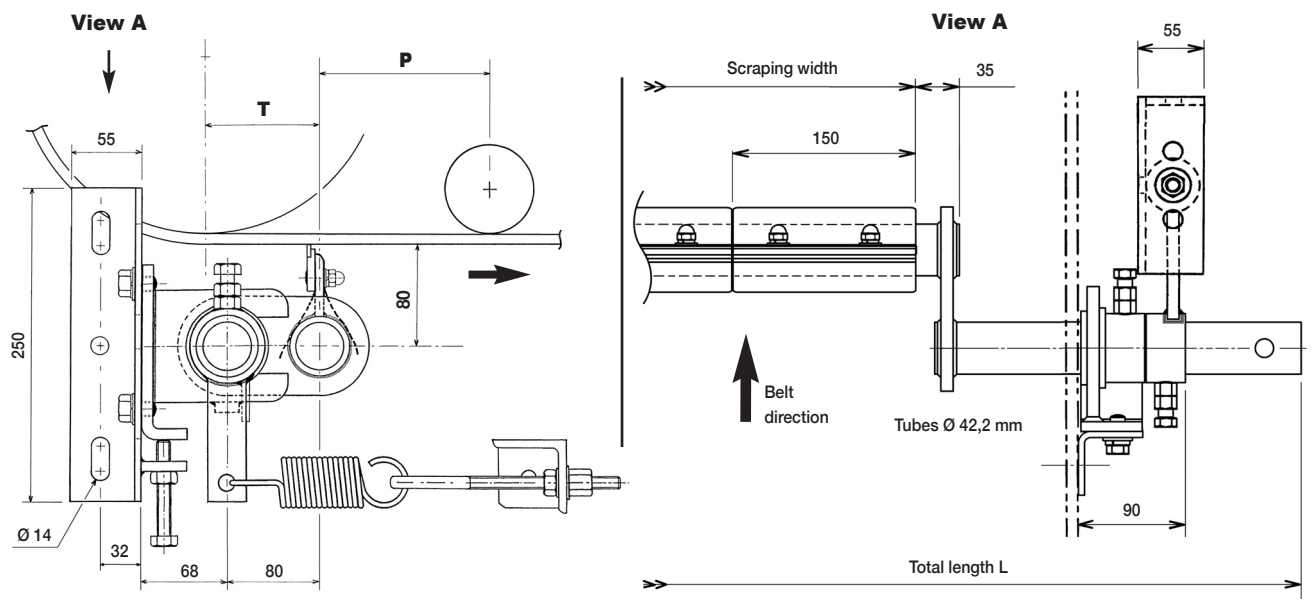

## STANDARD PRODUCTION RANGE

The mounting brackets can be installed towards the back.

REFERENCES	STOCK	BELT WIDTH	SCRAPING WIDTH	N° OF BLADES	PRESSURE SYSTEM	L	WEIGHT
<b>RDS 400 - RSA</b>	*	400	300	2	1	920	17 kg
<b>RDS 500 - RSA</b>	*	500	450	3	1	1070	18 kg
<b>RDS 650 - RSA</b>	*	600 - 650	600	4	1	1220	19 kg
<b>RDS 800 - RSA</b>	*	800	750	5	1 or 2	1370	20 kg
<b>RDS 1000 - RSA</b>		1000	900	6	2	1520	22 kg

Contact us for wider widths.

## DESIGNATION

The full designation includes the type of scraper, the belt width and the type of blade.

Example : **RDS 650 - RSA**

## SPARE PARTS

- Scraping blades : **RSA 150 / BRD**  
(Polysheet included)